

# IN CASE OF EMERGENCY:

Things everyone in the household should know

It's a great idea for every homeowner to set up an emergency plan and create a list of things everybody in the household should know. Your safety plan could involve maintaining a list of emergency shut-offs, information sources, and basic tools. You may need to find an expert to help locate, repair or maintain some of these valves and switches. Locating and tagging them would be a helpful exercise for any homeowner. I suggest you put a tag on each item and take a tour with all family members explaining what these items do and how to operate the controls. In addition, develop a list of emergency numbers and an escape plan. Here is a checklist to help get you started:

**▪ Main electrical disconnect.**

This will be located at the main fuse box or breaker panel. Usually there is one main switch or fuse block, but on older systems there can be multiple disconnects. (See Drawing E002, E003)

**▪ Water main valve.**

This valve turns off all the water to your home. If the valve looks old, worn or rusty, have a plumber check it for proper operation. If you use a municipal water supply, the valve will be located in the basement on the "street side" of your home near the water meter. If your house has its own

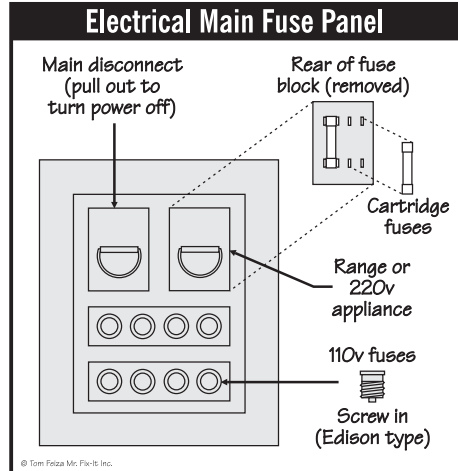

E003

well, the valve will be near the pressure tank. In this case, to disable the system, you must turn off the valve and the electrical switch for the well pump. (See Drawings P005, P056)

**▪ Hot water shut-off.** This valve is located on the cold-water inlet at the top of the water heater. It turns off the hot water supply to your home by closing the cold supply to the water heater. (See Drawing W012)

**▪ Natural gas main.** This will be located near the meter, either outside or inside your home. Many of these valves

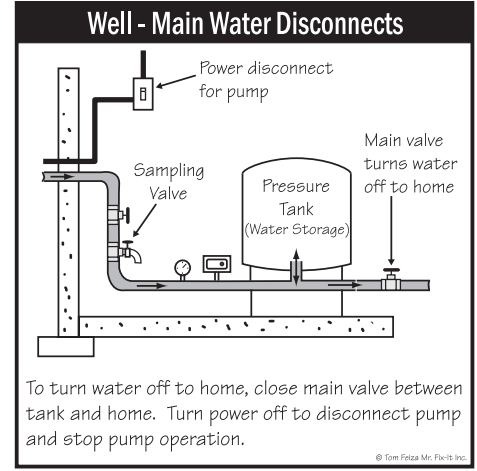

P056

require a wrench to operate; a quarter-turn moves the valve from on to off. When the handle is parallel to the pipe, the valve is open. (See Drawing P002)

**▪ Local gas valves.** These should be located at each gas appliance; they, too, close with a quarter-turn. (See Drawing P001)

**▪ Furnace and air conditioning main switch.** This is usually mounted on the furnace. In a modern system, it will look like a light switch. It turns off the central heating and cooling system. (See Drawing H008)

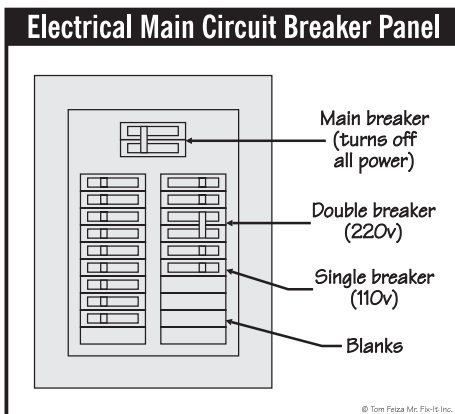

E002

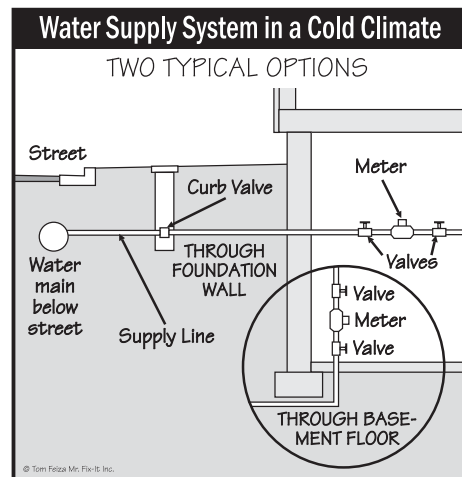

P005

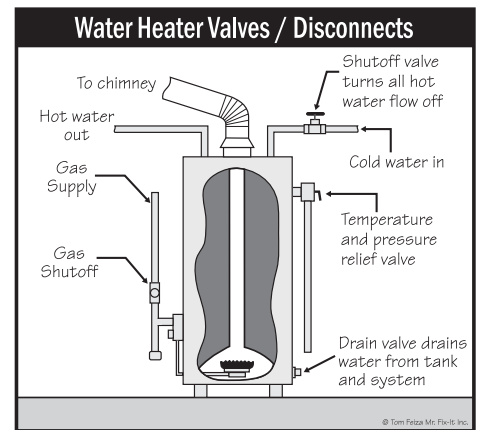

W012

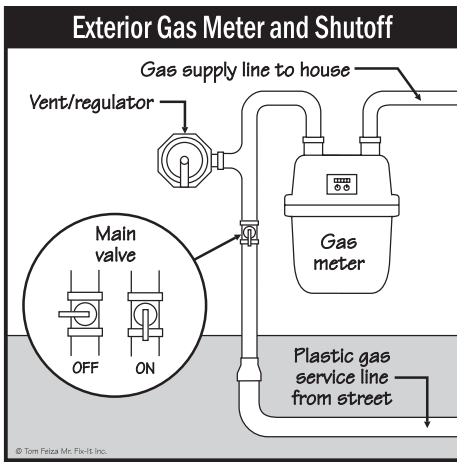

P002

**■ Air conditioning disconnect.**

This 240 Volt switch will be located next to the exterior part of the air conditioning system. (see Drawing A004)

**■ Emergency phone numbers.**

Keep a list of how to reach the fire department, ambulance/rescue, police, Mom, Dad, relatives, workplace(s), and others appropriate to your household.

**■ Fire extinguishers.** Place fire extinguishers in your kitchen, garage and basement. Make sure everyone knows how to use them.

**■ Emergency release for garage door.**

The automatic garage door opener has an emergency release so you can open the door when there is a power failure. Show everyone how it operates. Do this with the door down, because a poorly balanced door may crash to the ground. The release is located where the door attaches to the opener track. Pull the handle to release it—remember,

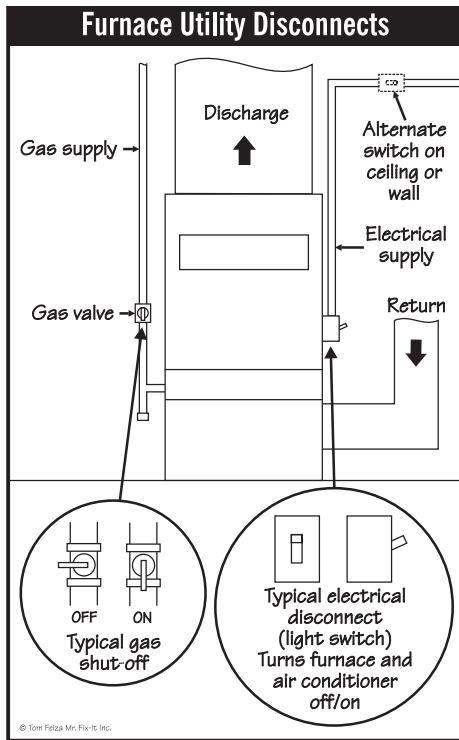

H003

do this with the door down—and then lift the door. (See Drawing M015)

**■ Emergency release for garage door—with a key (when there is no service door to the garage).**

In this situation, to release the garage door opener when the power is out, you

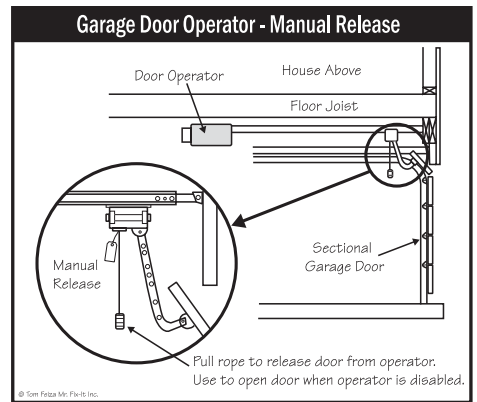

M015

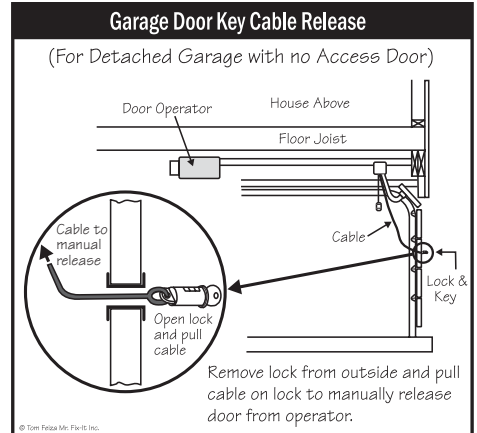

M018

must open a special lock and remove a cable. You'll find a circular lock near the top center of the garage door. Open this lock and pull the attached cable out through the opening. Doing this will release the opener from the garage door so you can open the door manually. Always remember that the door should be down before you test the release. (See Drawing M018)

Written by Tom Feiza – Mr. Fix-It. See Tom's book How To Operate Your Home (ISBN 0-9674759-3-7), for great information on "operating" a home. The book is available at [www.amazon.com](http://www.amazon.com) or through Tom at: [www.howtooperateyourhome.com](http://www.howtooperateyourhome.com) or [www.htoyh.com](http://www.htoyh.com), 262-786-7878.

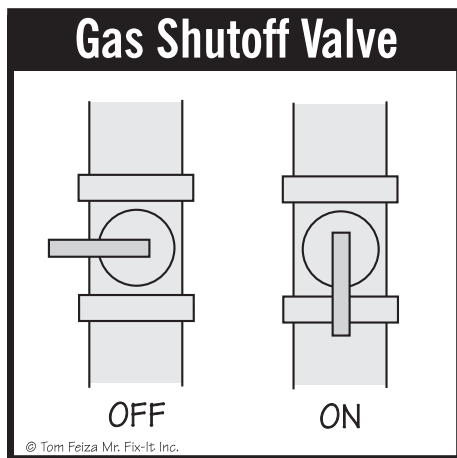

P001

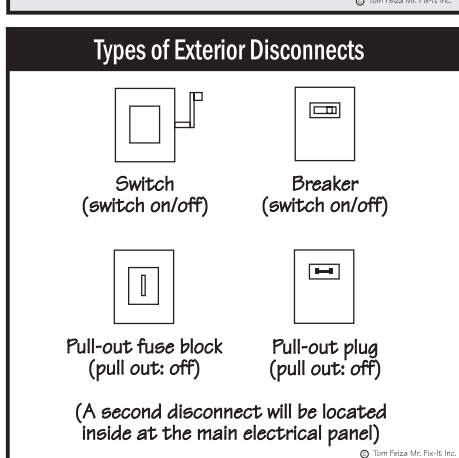

A004